

NEW!

Motor Actuators

MA-D03 MA-D04

**Pursued maximum downsizing "MA-D03".
Tolerant with high pressure and
high rotation speed "MA-D04".**

● **Environmentally friendly products**

Complied with RoHS & halogen free.

● **UL-CSA complied products**

International standards UL-CSA complied materials are used in our parts e.g. coil, lead wire, ..etc. They are able to assemble in export finished goods without modification.

● **Internal supply in China**

Lead time and delivery cost are reduced remarkably due to internal supply by our factory in Guang Dong Province, China.

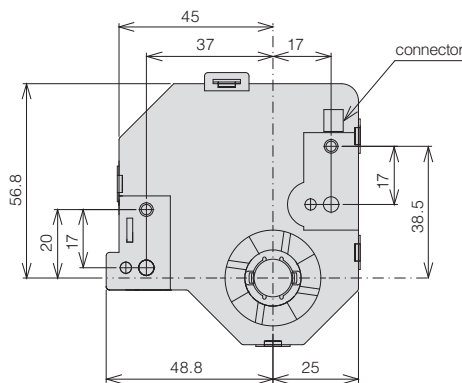
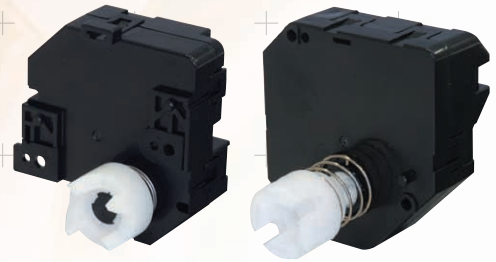

MA-D03

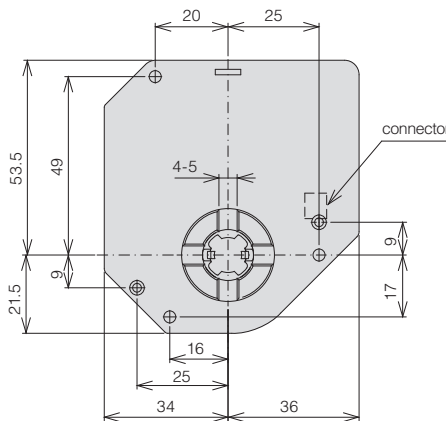

MA-D04

(Unit mm)

Type	MA-D03	MA-D04	
		LOW	HI
Rated Voltage	DC24V	DC24V	
Rated Torque	2.0N·m	2.0N·m	0.45N·m
Rated Rotation	1.8r/min	15.0r/min	90.0r/min
Rated Load Current	Below 100mA	Below 900mA	
No Load Rotation	2.8r/min	24.0r/min	110.0r/min
No Load Current	Below 30mA	Below 150mA	
Restraint Torque	Above 3.0N·m	Above 3.0N·m	Above 0.7N·m
Restraint Current	Below 350mA	Below 1.5A	

Application Paper feeder tray lifting for copy machine, printer ejector tray driving for copy machine, printer toner stirring for copy machine, printer.